

The PURELAB® Range

UNINTERRUPTED DISCOVERY

The laboratory water purification solutions for your research needs.



Contents

About ELGA 04

Your Water 06

Technologies 08

Product Range 10

Product Overview

<i>Quest</i>	12	<i>Pharma Compliance</i>	26
<i>Flex 1</i>	15	<i>Chorus 2+</i>	28
<i>Flex 2</i>	16	<i>Chorus 2</i>	30
<i>Flex 3</i>	17	<i>Chorus 3</i>	32
<i>Flex 4</i>	18	<i>Storage Reservoir</i>	34
<i>Flex 5 & 6</i>	19	<i>Remote Dispenser</i>	38
<i>Chorus 1</i>	22	<i>Halo Dispenser</i>	40
<i>Chorus 1 Complete</i>	24		

Product Specification 42

<i>Quest</i>	44	<i>Chorus 1 Complete</i>	51
<i>Flex 1 & 2</i>	46	<i>Pharma Compliance</i>	52
<i>Flex 3 & 4</i>	47	<i>Chorus 2+</i>	53
<i>Flex 5 & 6</i>	48	<i>Chorus 2 & 3</i>	54
<i>Chorus 1</i>	50		

Index 56

ELGA. We are the LabWater Specialists

We are the specialists in the engineering, service & support of water purification systems. Our unrivalled product design has achieved international recognition and awards. We have been working with scientists since 1937 to guarantee ultrapure and pure water for their experiments and laboratory work.

Why choose ELGA as your laboratory water partners?



Customer-focused – what we create is for our customer

Our commitment to developing and providing you with ultrapure water means that you can focus and concentrate on obtaining accurate and reliable results.



Innovative – the keystone of our thinking

Our UK R&D facilities are always looking to provide products dedicated to supplying you with the right water quality for your application.



Sustainable – at the forefront of all of our activities

Our products are designed to have the lowest possible impact on the environment at all stages: manufacture, in service and at end of life. We can calculate the carbon value of all our products through their lifetime.



British Engineering and Manufacturing – the standard for all our products

All our systems are manufactured in the UK and we are accredited to ISO:9001 and ISO:14001 standards.

Our technical service teams support our global science & healthcare customers with specialist expertise. Global digital performance monitoring ensures laboratory work is uninterrupted, and a global supply chain supports clients from regional centres on every continent.

Our Awards



The choice *you* need, for *your* lab

We understand how important it is for you to obtain a choice of water qualities that range from Reverse Osmosis grade for simple routine washing and rinsing, through to ultrapure water for the most critical applications. The PURELAB product range has a wide variety of water purification systems that will meet any one of your requirements for water quality.

What are the different types of water quality and what are they used for?

Type I Water

Often referred to as ultrapure water, this grade is required for some of the most water-critical applications such as HPLC (High-Performance Liquid Chromatography) mobile phase preparation, blanks and sample dilution for other key analytical techniques such as GC (Gas Chromatography), AAS (Atomic Absorption Spectrophotometry), and ICP-MS (inductively Coupled Plasma Mass Spectrometry) as well as molecular biology applications.

Type II Water

Is the grade for general laboratory applications such as media preparation, pH solutions, buffers and used as a feed source to Type I systems.

Type III Water

Is the grade of water recommended for non-critical work which may include glassware rinsing, water baths, autoclave, environmental chambers as used to feed Type I systems.

There is a PURELAB® product to suit your specific needs

TYPE I*	TYPE II	TYPE III
PURELAB Quest	PURELAB Quest	PURELAB Quest
PURELAB Flex 1**, 2, 3, 4, 5 & 6	PURELAB Chorus 2 RO/EDI/UV	PURELAB Chorus 3
PURELAB Chorus 1 Analytical Research*	PURELAB Chorus 2 RO/DI/UV	PURELAB flex 1**, 3, 4, 5 & 6
PURELAB Chorus 1 Life Science*	PURELAB Chorus 2 RO/DI	
PURELAB Chorus 1 General Science*	PURELAB flex 1**, 3, 4, 5 & 6	
PURELAB Chorus 1 Complete		
PURELAB Pharma Compliance*		

*PureSure Technology/in-line filtration/variety of purification packs. **Dependent on feed water.

Our comprehensive range of products

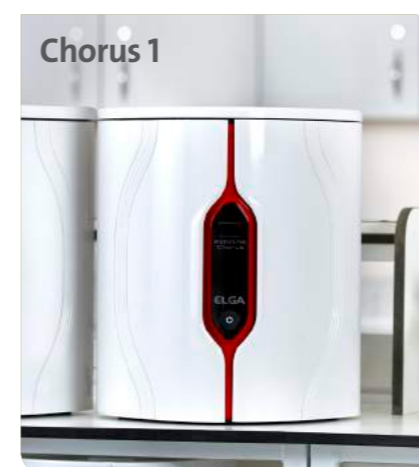

Technologies

The various technologies used in ELGA equipment are able to remove impurities from water down to extremely low levels; some technologies focus on specific contaminants while others have a broader spectrum of targets. To achieve the correct water purity for a particular application, in a cost effective manner, technologies must be arranged in combination and their operation optimized.

Activated Carbon

Contains a maze of tiny pores with sizes ranging from <math><0.1 - 2.9\text{ nm}</math> and a surface area of about 1000 square meters per gram. The nature of this surface allows adsorption of organic impurities from the water and catalytic decomposition of free chlorine and, more slowly, chloramines.

It is applied in:

- Pre-treatment cartridges
- Composite vent filters
- Final purification cartridges

Microporous Depth Filters

Pre-filtration using microporous depth filters, provides an entrapment/adsorption barrier for the removal of large suspended particles and some colloids from the water entering the ELGA purification process. Typically rated at 5 – 10 μm and combined with an activated carbon treatment, these filters act to protect subsequent RO systems from fouling and blockage.

Small and Large Organic Molecules

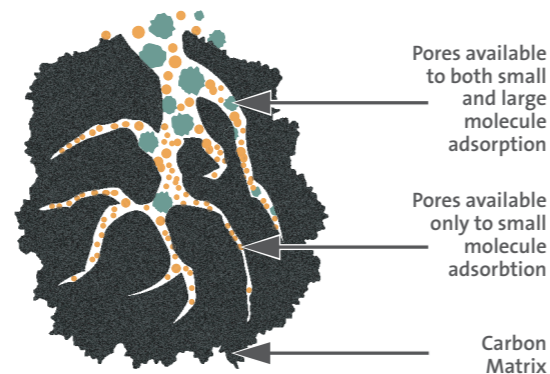

Reverse Osmosis

Reverse osmosis (RO) is a process where pressure is used to push water through a membrane filter in a cross-flow fashion. RO membranes are extremely fine filters that reject water contaminants less than 1nm in diameter. Typically >95% of ionic impurity, most organic impurity, and nearly all particulates, bacteria and bio-molecules are removed from the permeate water; these are carried out of the RO module in a waste or concentrate water stream.

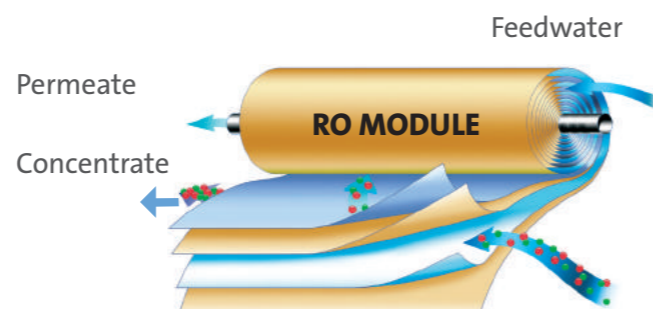

Technologies

Ion Exchange

Ion exchange resins are often used as part of a final treatment step. Single-use purification packs typically use a mixture of ion-exchange resins and other media. When used to deionize water, charged impurities are retained on these resins, while H^+ and OH^- ions (which combine to form water) are released to replace them. This is a highly efficient process and can remove ions to give product-water resistivity of up to 18.2 $\text{M}\Omega\cdot\text{cm}$.

Electrodeionization

Electrodeionization (EDI) combines ion-exchange resins and ion-selective membranes, which are used to move ionic impurities into a waste or concentrate water stream leaving purified product-water. As impurities leave via the concentrate water stream, their build-up does not exhaust the resin, and therefore prolongs resin lifespan. A single EDI unit may operate for many years before a replacement is required. Typically product water resistivity of >10 $\text{M}\Omega\cdot\text{cm}$ is consistently achieved using this process. This technology can be used as an alternative to single-use purification cartridges.

Ultraviolet (UV) Light

Treatment of water with UV-C light is used to photo-oxidise organic impurities and/or inactivate micro-organisms. Photo-oxidation of organic impurities results in polar or charged species that can subsequently be removed by ion-exchange processes. Typically the UV lamp forms part of a 'polishing' treatment loop including ion-exchange, through which water is repeatedly circulated to maintain quality. Water with Total Organic Carbon (TOC) of <5 ppbC and bacteria at <1 CFU/ml can be achieved in ELGA products that use this approach.

Sub-micron Filtration

Sub-micron filtration, including micro, ultra-micro and ultra filters (30–3000 nm) are used as part of a 'polishing' loop or at the point-of-use. Fine filtration is applied to remove bacteria (live or dead) and biologically active molecules. These absolute filters have pores smaller than their intended target and can retain the impurity while allowing water to pass through. Impurities that are removed by sub-micron filtration, include bacteria, colloids, enzymes, endotoxins and particulates.

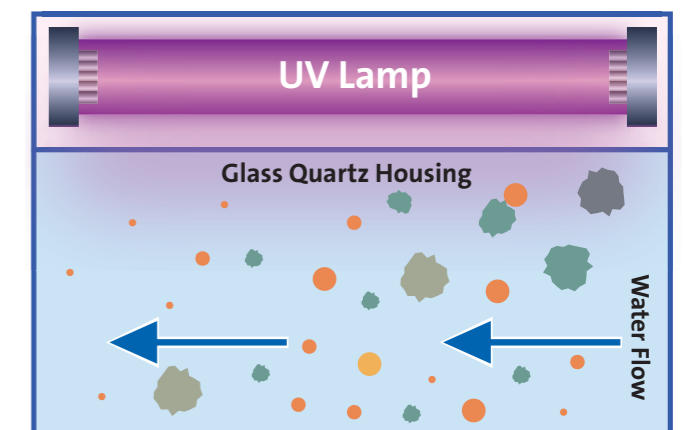

PURELAB®

Product Range



PURELAB[®] Quest

The only purifier on the market that dispenses all 3 types of science ready water from a compact, economical and easy to use system. The Quest water solution system provides laboratory water directly from a tap water input.

AT A GLANCE

Overview:

- **Type I** - 18.2 MΩ.cm (Up to 10 Litres per day)
- **Type II** - > 1 MΩ.cm (Up to 10 Litres per day)
- **Type III** - 20 μS.cm (Up to 30 Litres per day)

Key Features:

- Compact
- Connected
- Sustainable
- Cost effective
- Proven reliability which is tested, proven and unrivalled
- Effortless, ingenious, intuitive

Ideal Applications:

- **Type I Water**
HPLC
GC-MS
AA/ICP-OES
IC
Molecular biology e.g. DNA Sequencing and PCR
- **Type II Water**
Preparing and diluting buffers and reagents
Tissue culture media
pH solutions
- **Type III Water**
Glassware rinsing
Water baths
Autoclave feeds

Compact

232 mm wide. 510 mm high. Wall mountable; saving valuable lab space.

Sustainable

Made from more than 85% reclaimed materials.*
Designed with long lasting consumables.

Cost-Effective

3 types of water from one system. Space saving design means a more efficient lab and team.

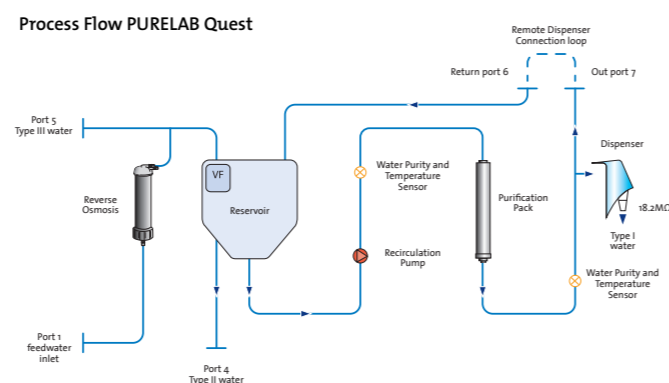

3 types of water from one system.
Space saving design means a more
efficient lab and team.



*Excludes materials in contact with the purification process.

See specification on page 40

The flex Range

flex 1



flex 2



flex 3



flex 4



flex 5



flex 6



PURELAB[®] flex 1

Simplicity and Elegance

The best dispenser for your distribution system.

The PURELAB flex 1 is designed as a dispensing and monitoring system when connected to a reservoir or distribution loop. It also works as a simple deionization system.

AT A GLANCE

Overview:

- Type I
- Type II
- Type III

Dependant on use of DI pack
Litres per day: Dependant on
feed water

Key Features:

- Flexible dispensing
- Customise settings
- Full re-circulating
- Integrated filtration

Ideal Applications:

- General Lab
- Type II Applications
- Dispensing with DI Pack

Customized Settings

Be in control of your PURELAB flex by customizing the settings to suit your application.

Simplicity

Simple to install, operate and maintain with prioritized information displayed at all times (system status, alarm) for absolute confidence as you dispense.

Easy to Use

Ergonomic design with features including auto volumetric dispense and height adjustability.

Data Capture

Data capture via USB for system performance validation and software updates.

Space Saving

Space saving and compact dispenser which can be placed on the bench or wall mounted.

See specification on page 42

PURELAB[®] flex 2

Designed for the laboratory of today

Reliable delivery of Type I water purity.

The PURELAB flex is designed to deliver accuracy, flexibility and ease-of-use.

The award winning system produces ultrapure type I (18.2 Ω.cm) water from a pre-purified feed, which is ideal for analytical and life science applications.

It allows focus on routine test work without concern about the water quality affecting test results.

AT A GLANCE

Overview:

- Type I - 18.2 MΩ.cm
- Litres per day:
Dependant on feed water

Key Features:

- Real-time TOC
- Fully re-circulating
- Customize settings
- Integrated filtration
- Adjustable dispensing

Ideal Applications:

- Mass Spectrometry
- Molecular Biology
- Electrochemistry
- Atomic Spectroscopy
- Liquid Chromatography
- Gas Chromatography
- Immunochemistry
- Spectrophotometry
- Media / Buffer Prep
- General Chemistry

Full Spectrum UV Treatment

Full recirculation through the UV lamp and purification pack right to the point of use for peace of mind.

Intuitive Flexible Dispense

Clear water purity display for absolute confidence as you dispense.

Real-time TOC Monitoring

Provides complete confidence in organic purity by reducing the level of organics for critical applications.

Easy to Maintain

Easy access to the consumables as well as well as quick easy automated sanitization to minimize downtime.

Data Capture

Data capture via USB for system performance validation and software updates.

Space Saving

Space saving and compact dispenser which can be placed on the bench or wall mounted.

See specification on page 42

PURELAB[®] flex 3

Power and flexibility

A small unit with big power capabilities.

The PURELAB flex 3 is the ultimate system providing Type 1 ultrapure water from potable tap water in one single unit.

AT A GLANCE

Overview:

- Type I - 18.2 MΩ.cm
- Litres per day: < 10

Key Features:

- Real-time TOC
- Fully re-circulating
- Integrated filtration
- Adjustable dispensing

Ideal Applications:

- Mass Spectrometry
- Molecular Biology
- Electrochemistry
- Atomic Spectroscopy
- Liquid Chromatography
- Cell Culture
- Gas Chromatography
- Immunochemistry
- Spectrophotometry
- Media / Buffer Prep
- General Chemistry

Space Saving Design

The compact unit can be placed on the bench or wall mounted and has an integrated 7 Litre reservoir filled by a 10 l/hr RO membrane, ensuring that water is always available.

Full Recirculating

Ensuring the highest microbial purity and guaranteeing pure water, as recirculation of the water occurs from the reservoir right to the point-of-use.

Flexible Dispenser

The intuitive dispenser offers a clear display of the water purity for absolute confidence as you dispense.

Real-time TOC Monitoring

Provides complete confidence in organic purity and clear display at all times. The final quality sensor is placed at the entry of the flexible dispenser giving you peace of mind.

Simplicity

Simple to install, operate and with a quick semi-automated sanitization to minimize downtime.

Data Capture

Data capture via USB for system performance validation and software updates.

See specification on page 43

PURELAB[®] flex 4

Flexible elegance

An independent system. PURELAB flex 4 produces ultrapure (Type I) water from pre-purified water, with its manual-filling capability, it is able to operate independently from a fixed water source in temporary locations. It has an integrated 7 Litre reservoir, ensuring that water is always available and is particularly suited for small volumes of water where TOC levels are critical and must remain stable.

AT A GLANCE

Overview:

- Type I - 18.2 MΩ.cm
- Litres per day: Dependant on feed water

Key Features:

- Real-time TOC
- Fully re-circulating
- Customize settings
- Integrated filtration
- Adjustable dispensing

Ideal Applications:

- Mass Spectrometry
- Molecular Biology
- Electrochemistry
- Atomic Spectroscopy
- Liquid Chromatography
- Gas Chromatography
- Immunochemistry
- Spectrophotometry
- Media / Buffer Prep
- General Chemistry

Space Saving Design

The compact unit can be placed on the bench or can be wall mounted and has an integrated 7 Litre reservoir, ensuring that water is always available.

Full Recirculating

Ensuring the highest microbial purity and guaranteeing pure water, as recirculation of the water occurs from the reservoir right to the point-of-use.

Flexible Dispenser

The intuitive dispenser offers a clear display of the water purity for absolute confidence as you dispense.

Real-time TOC Monitoring

Provides complete confidence in organic purity and clear display at all times.

Simplicity

Simple to install, operate and with a quick semi-automated sanitization to minimize downtime.

Data Capture

Data capture via USB for system performance validation and software updates.

Portable System

Access on the top of the system gives the option to fill the reservoir with pre-purified water. This means that it can be moved at any time as the lab environment evolves.

See specification on page 43

PURELAB[®] flex 5 & 6

Unique automated solution.

The PURELAB flex 5 & 6 is a unique automated solution. It provides Type I (ultrapure water) from potable water (flex 5) or RO and is designed to couple directly with analytical chemistry systems delivering complete automation - all in one single unit.

AT A GLANCE

Overview:

- Type I - 18.2 MΩ.cm
- Litres per day: <10

Key Features:

- Connects directly to multiple analytical chemistry systems from multiple brands
- On-demand continuous ultrapure water to analysers
- Full automation of water production & delivery
- Real-time TOC monitoring
- Full re-circulating
- Adjustable dispensing

Ideal Applications:

- Analytical Chemistry systems
- Mass Spectrometry
- Molecular Biology
- Electrochemistry
- Atomic Spectroscopy
- Liquid Chromatography
- Cell Culture
- Gas Chromatography
- Immunochemistry
- Spectrophotometry

On-demand Water Supply

Provides consistent & continuous supply of ultrapure water to analysers to reduce failed runs and loss of samples, reagents and analyser components/accessories.

Space Saving Design

The compact unit can be placed on the bench or can be wall mounted and has an integrated 7 Litre reservoir filled by a 10 l/hr RO membrane, ensuring that water is always available.

Full Recirculating

Ensuring the highest microbial purity and guaranteeing pure water, as recirculation of the water occurs from the reservoir right to the point-of-use.

Real-time TOC Monitoring

Provides complete confidence in organic purity and clear display at all times. The final quality sensor is placed at the entry of the flexible dispenser giving you peace of mind.

Data Capture

Monitor water purity via USB datalog ensuring analytical performance during test batch

See specification on page 44

The Chorus Range

Chorus 1



Chorus 1 Complete



Pharma Compliance



Chorus 2+



Chorus 2



Chorus 3



PURELAB[®] Chorus 1

Flexible. Configurable. Simple.

Delivering the ultimate in water purity for absolute confidence in your results. When you require the ultimate in water purity, PURELAB Chorus 1 provides the perfect solution. Consistently delivering water purity of 18.2 MΩ.cm (Type I+/I) and underpinned by the advanced PureSure[®] deionization system.

AT A GLANCE

Overview:

- Type I+ Water
- 18.2 MΩ.cm
- Litres per day:
Depends on feedwater

Key Features:

- Real time TOC
- Fully re-circulating
- Integrated filtration
- Multiple dispensing
- PureSure technology

Ideal Applications:

- Mass Spectrometry
- Ion Chromatography
- Ultra trace Analyses
- Qualitative Analyses
- Gas Chromatography
- Molecular Biology
- Cell Cultures
- Electrochemistry
- Immunochemistry
- Atomic Spectroscopy

Advanced PureSure Deionization

A twin-bed ion-exchange process with inter-stage resistivity monitoring allows retention of any impurity released during exhaustion of a primary cartridge, by the secondary polishing cartridge. This method gives guaranteed, optimum, product-water quality, advanced warning of consumable change, and extended consumable service life.

Fully Recirculating

Ensuring microbial purity and guaranteeing pure water at the point-of-use.

Real-time TOC Monitoring

Provides complete confidence in organic purity.

Integrated Filtration

Ultrafiltration or microfiltration filters out endotoxins, proteins, nucleases and particulates. 185nm wavelength breaks organic compounds and 254nm wavelength sterilises bacteria and viruses.

Data Capture

Data capture via USB for system performance validation and software updates.

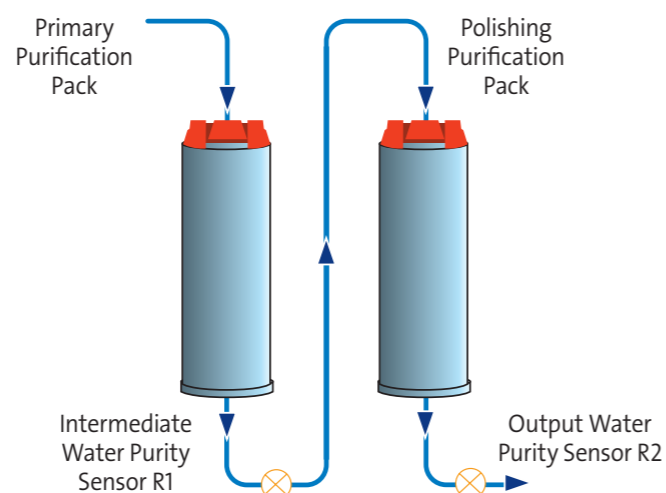

Chorus 1 enables you to focus on attaining accurate results while ensuring an uninterrupted work flow



See specification on page 44

PURELAB[®] Chorus 1 Complete

Flexible. Configurable. Simple.

One complete solution for the laboratory.

PURELAB Chorus 1 Complete provides a complete solution from potable tap water supply to ultrapure water, and is ideal for laboratories needing up to 480 Litres of 18.2 MΩ.cm ultrapure water. With its easy to use ergonomic design, water can be measured and dispensed with confidence directly from the system or from a choice of additional Halo Dispensers.

AT A GLANCE

Overview:

- Type I Water - 18.2 MΩ.cm
- Litres per day: Up to 480
- Type II Water from Reservoir

Key Features:

- Tap-to-ultrapure
- Fully re-circulating
- Integrated filtration
- Multiple dispensing

Ideal Applications:

- Mass Spectrometry
- Molecular Biology
- Electrochemistry
- Atomic Spectroscopy
- Liquid Chromatography
- Gas Chromatography
- Immunochemistry
- General Laboratory
- Spectrophotometry

Fully Recirculating

Recirculation of purified water through our modular reservoir to maintain consistent peak water purity at 18.2 MΩ.cm.

ELGA Biofilter (optional)

When fitted, PURELAB Chorus 1 Complete produces water which is free from biologically active impurities.

Single System Solution

Perfect single system solution for analytical and life science applications requiring 18.2 MΩ.cm.

Data Capture

Data capture via USB for system performance validation and software updates.

Reduced Maintenance Times

Quick and easy replacement of consumables as well as semi-automated sanitization to reduce maintenance times.

Space Saving Design

Designed to be modular and stackable to save space, whether wall-mounted or under the bench.

Economical

Optional CO₂ removal from the purified water (post RO) increasing the life of downstream consumables.



Chorus 1 Complete provides a complete solution from potable tap water supply to ultrapure water

See specification on page 45

PURELAB[®] Pharma Compliance

PURELAB Pharma Compliance is packed with innovative features optimised for QC laboratories. It offers all the necessary purification, software capabilities, qualification documentation and online support services necessary for the validation required to meet Good Manufacturing Practice (GMP). The ultrapure water system meets your laboratories needs, with minimal intervention, improved efficiencies and a contemporary style to compliment any modern laboratory.

The Pharma Compliance includes secure software providing the evidence to meet FDA and EU standards for digital record keeping. Purification processes fulfil United States Pharmacopeia standards 643 and 645. Qualification documents provided enable the unit to support labs subject to validation under GxP.

AT A GLANCE

Overview:

- Type I Water - 18.2 MΩ.cm

Key Features:

- Smart, intuitive software
- Digital record keeping
- Quality management system
- Meets GMP requirements
- Complies with the TOC verification and water conductivity measurements required under US pharmacopeia 643 and 645.

Ideal Applications:

- QC labs wanting to meet high level GMP regulations
- QC labs with FDA CFR 21 Part 11 requirements
- Mass spectrometry
- Ion and Gas chromatography
- Ultra trace and qualitative analyses
- Molecular Biology
- Cell cultures
- Electrochemistry
- Immunochemistry

Digital Record Keeping

The PURELAB Pharma Compliance's admin functions, security and data integrity capabilities, password accessibility, audit trail procedures & permissions all meet national regulators best practice for data management in QC labs following GMP standards.

Designed to Comply

Designed to meet FDA, United States Pharmacopeia, EUDRALEX, European Pharmacopoeia and all GMP requirements for Quality Control laboratories.

Cost Effective

The PURELAB Pharma Compliance delivers the water to support the QC tests necessary to validate drug purity in pharma manufacturing. Consumables are designed to minimise cost and waste.



See specification on page 52

PURELAB[®] Chorus 2+

Flexible. Configurable. Simple.

One complete solution for the laboratory.

PURELAB Chorus 2+ (RO/EDI/UV) features our patented recirculating EDI technology: the only EDI system on the market that is able to fully recirculate to achieve 10- >15 MΩ.cm. The PURELAB Chorus 2+ provides additional bacteria and inorganic quality for sensitive analytical and life science applications above that of basic laboratory work. With its simple design and ease of use, water can be measured and dispensed with confidence from the system or from a choice of additional Halo or Remote Dispenser.

AT A GLANCE

Overview:

- Type II+ Water
- 10 MΩ.cm
- Litres per day:
Up to 216

Key Features:

- Tap to Type II
- Fully Re-circulating
- Multiple Dispensing

Ideal Applications:

- Electrochemistry
- Cell Culture
- Spectrophotometry
- Feed to Ultrapure Water
- Media / Buffer Preparation
- General Chemistry

Fully Recirculating

ELGA's patented fully recirculated EDI provides a constant supply of high purity that guarantees a minimum of 10 MΩ.cm water at all times.

Ideal for High Volume Labs

A cost-effective solution for laboratories requiring higher output volumes thanks to the incorporated EDI technology.

Single System Solution

Perfect single system solution for analytical and life science applications.

Space Saving Design

Designed to be modular and stackable to save space, whether wall-mounted* or under the bench.

**If fitted with Halo dispenser*

Reduced Maintenance Times

Quick and easy replacement of consumables as well as semi-automated sanitization to reduce maintenance times.

Economical

Optional CO² removal from the purified water (post RO) increasing the life of downstream consumables.

Data Capture

Data capture via USB for system performance validation and software updates.



With its simple design and ease of use, water can be measured and dispensed with confidence

See specification on page 53

PURELAB® Chorus 2

Modular. Flexible. Reliable.

Reliable delivery of Type II water purity.

When Type II water is all you need, then PURELAB® Chorus 2 (RO/DI) is the reliable solution with the flexibility to suit your requirements. It dispenses up to 480 Litres of pure water per day from a potable water supply for general laboratory applications.

AT A GLANCE

Overview:

- Type II - 10 MΩ.cm
- Litres per day:
Up to 480

Key Features:

- Easy Configurability
- Modular

Ideal Applications:

- Stills Replacement
- Buffer Preparation
- pH solution Preparation
- Washing/Rinsing
- Autoclaves
- General Chemistry
- Hydroponics
- Steam Generators
- Sterilizer Feed
- Feed to Type I Polishers

Deionization

The Reverse Osmosis feed contains optimized resin mixes to maximize consumables capacity.

Simplicity

Simple to install, operate and maintain with prioritized information displayed at all times (system status, alarm) for absolute confidence as you dispense.

Economical

Optional CO² removal from the purified water (post RO) increasing the life of downstream consumables.

Option to reduce water consumption for low hardness feed waters.

Modular

Multiple PURELAB Chorus 2 units can feed into one reservoir and systems can be expanded post-installation. As such, the cost of future upgrades is minimized. Duplex systems also guarantee maximum uptime.

Data Capture

Data capture via USB for system performance validation and software updates.

Reduced Maintenance Times

Quick and easy replacement of consumables as well as simple sanitization to reduce maintenance time.

PURELAB Chorus 2 (RO/DI) is the reliable solution with the flexibility to suit your requirements



See specification on page 54

PURELAB[®] Chorus 3

Modular. Flexible. Reliable.

Reliable delivery of Type III water purity. When general laboratory grade water is all you need, then PURELAB Chorus 3 is the reliable solution with the flexibility to suit your requirements. It can also be used as a feed to other ELGA water systems.

AT A GLANCE

Overview:

- Type III Water
- 10 MΩ.cm
- Litres per day:
Up to 720
- RO Water

Key Features:

- Easy Configurability
- Auto Rinse
- Modular

Ideal Applications:

- Buffer Preparation
- Washing/Rinsing
- Autoclaves
- General Chemistry
- Hydroponics
- Steam Generators
- Sterilizer Feed
- Feed to Type I polishers

Configuration

Ability to configure multiple systems to increase flow rate.

Simplicity

Simple to install, operate and maintain with prioritized information displayed at all times (system status, alarm) for absolute confidence as you dispense.

Economical

Optional CO2 removal from the purified water (post RO) increasing the life of downstream consumables.

Option to reduce water consumption for low hardness feed waters.

Auto Rinse

Maintains purity of water during periods of low use.

Data Capture

Data capture via USB for system performance validation and software updates.

Reduced Maintenance Times

Quick and easy replacement of consumables as well as semi-automated sanitization to reduce maintenance time.

Modular

Multiple PURELAB Chorus 3 units can feed into one reservoir and systems can be expanded post-installation. As such, the cost of future upgrades is minimized. Duplex systems also guarantee maximum uptime.

The reliable solution for general laboratory grade water



See specification on page 47

Storage Reservoirs

Our unique range of storage solutions are designed to maintain optimum purity of stored water and provide effective protection against airborne contaminants. They are designed to accommodate PURELAB Chorus water purification systems by maximizing the space in a single integral, compact unit or to sit independently to suit the layout of your laboratory.

Multiple Positioning

Multiple positioning/mounting options to suit your laboratory layout.

Polyethylene Construction

Inert opaque polyethylene construction with smooth inner surface.

Dispense Tap

Positioned to minimize accidental operation or damage (choice of positions).

Advanced Vent Filtration

Prevents the ingress of airborne bacteria, particulates, organic vapours and CO₂.

Auto Fill

Monitoring of reservoir water levels with automated refill ensures purified water is always available.

Hygienic Overflow

Hygienic overflow in the unlikely event of water system malfunction.

Easy Display

Direct display of stored purified water on the front of the reservoir for easy identification.

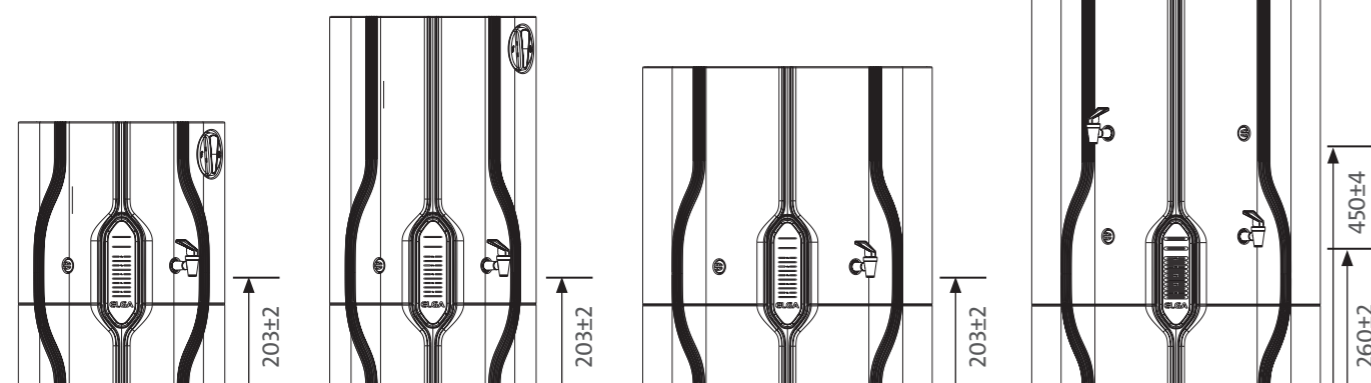

Capacity: 15 Litres
Dimensions (mm):
485 (h) x 376 (w) x 347 (d)*
Flow Rate: 6 l/min

Capacity: 30 Litres
Dimensions (mm):
676 (h) x 376 (w) x 347 (d)*
Flow Rate: 8 l/min

Capacity: 60 Litres
Dimensions (mm):
590 (h) x 532 (w) x 534 (d)*
Flow Rate: 10 l/min

Capacity: 100 Litres
Dimensions (mm):
805 (h) x 532 (w) x 524 (d)*
Flow Rate: 10 l/min

* Please allow for ±8mm tolerance





PURELAB[®]
Dispensing Solutions

PURELAB® Dispenser

The only remote dispenser on the market with an in-built water quality monitor – providing maximum reassurance that you are not losing purity as you move to a free-standing solution. Together with PURELAB Chorus & Quest you can quickly and easily create a bespoke water purification solution for your lab. The PURELAB Dispenser enables uninterrupted discovery.

AT A GLANCE

Overview:

- Type I Water
- 18.2 MΩ.cm
- Litres per day:
Up to 480

Key Features:

- Unrivalled purity in design
- Unmatched flexibility
- Effortless use
- Simple & easy installation

Ideal Applications:

- Life Science applications (cell culture, PCR, genomics, dissolution testing, western blotting)
- Chromatographic techniques
- (HPLC, UHPLC, LC-MS, IC, ICP-MS, AAS)

Accuracy

- Flexible dispensing with unrivalled built in purity monitoring sensor
- Delivering proof of water purity
- Repeated volume dispensing
- Improving lab efficiency
- Reproducible results

Streamlined footprint

- Maximized lab space
- Optimization of storage space
- Up to 4 dispensers per water purifier*

*Dependent on water purifier purchased.

Simple use and maintenance

- Plug and Play installation with PURELAB range
- Height adjustable, 180° rotating arm and flexible dispenser arm
- IPX7 rating dispenser handset with menu navigation
- Optional connection to point of use filtration

Efficient

- From precise drop by drop up to 2 litres per minute allowing for the right speed including calibration work
- Variable flow rate for easier filling of different sizes of labware
- Volumetric dispensing freeing you to continue working while water is being dispensed
- Profile & locked dispensing allowing you to choose your desired amount of water and prevent accidental flooding



Halo Dispense Solutions

The PURELAB range offers a variety of dispensing and monitoring solutions to customers enabling the ultimate flexibility when using PURELAB Chorus 1, Chorus 1 Complete, & Quest.

Clear Display

Prioritized information displayed at all times (system status, alarm) for absolute confidence as you dispense.

Multiple Positioning

Position the dispenser on the benchtop or independent from the water purification system to optimise your valuable lab space.

Flexible Dispensing

- Variable flow
- Auto-volume dispense
- Hands free
- Locked dispense
- Hand-held dispensing
- Profile dispense

Halo Glow*

The unique glow changes colour and flashes alerting you to changes in the system performance.

Water monitoring & Real-Time TOC Monitoring**

Water is monitored right to the point of dispense for complete peace of mind and real time TOC monitoring for critical applications.

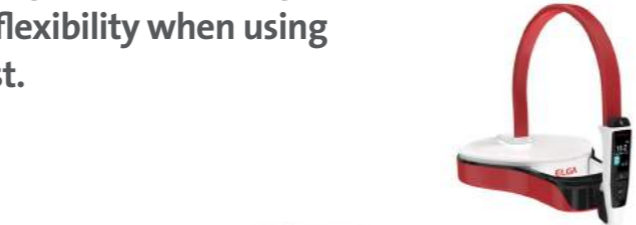

Halo Dispenser	Halo Advanced Dispenser	Halo Flexible Dispenser
Fixed	Fixed	Flexible
<ul style="list-style-type: none"> • Variable flow rate dispense • Drop-by-drop control • Locked dispense 		
		<ul style="list-style-type: none"> • Purity monitoring to point-of-use • Auto volume dispense • Profile dispense
		<ul style="list-style-type: none"> • Flexible handset



A choice of four dispensing solutions are available to suit different applications, budget and configuration



*Only for PURELAB Chorus range
**Only for PURELAB Chorus 1

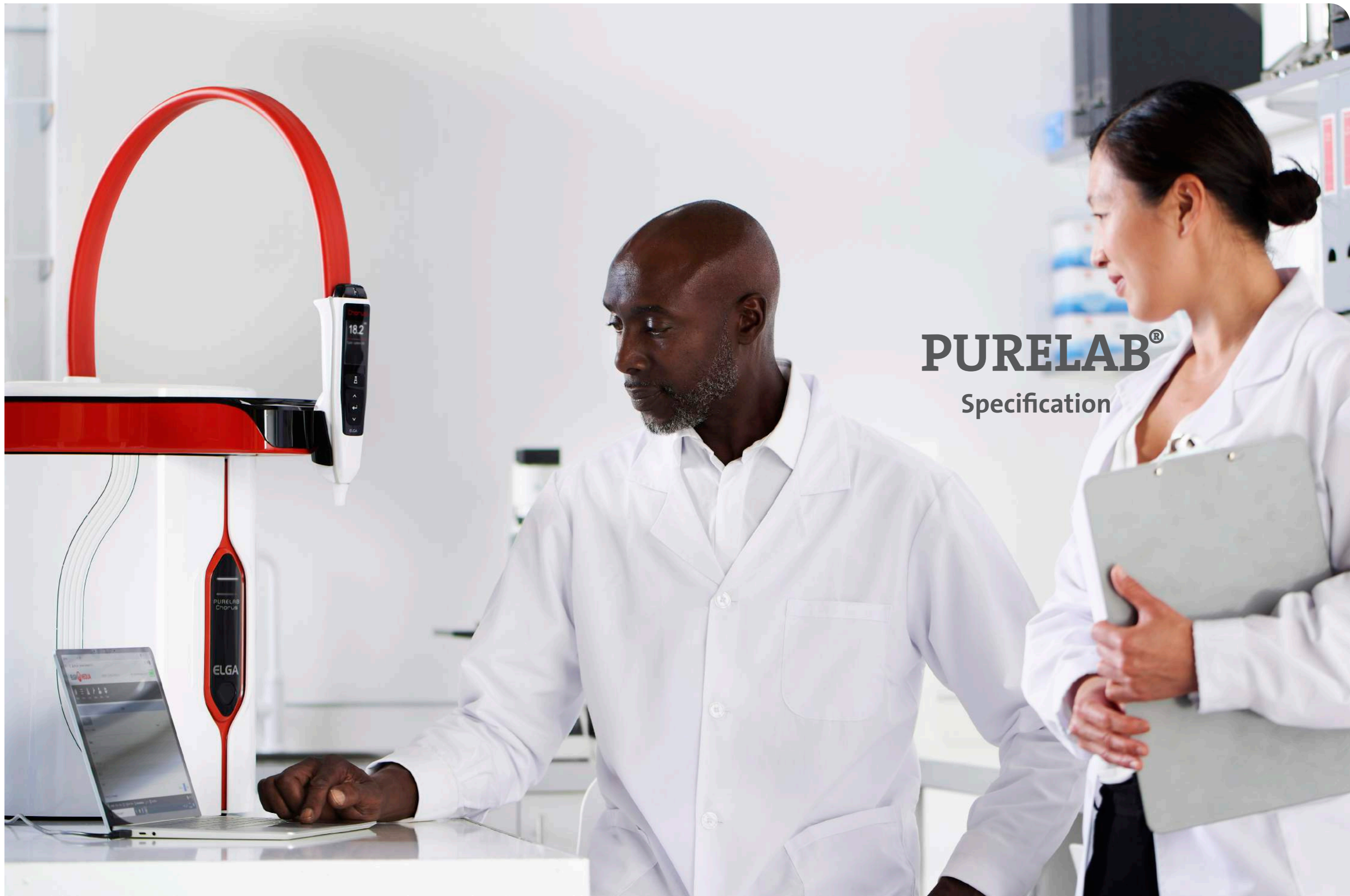

PURELAB®

Specification

Quest



Process Flow PURELAB Quest

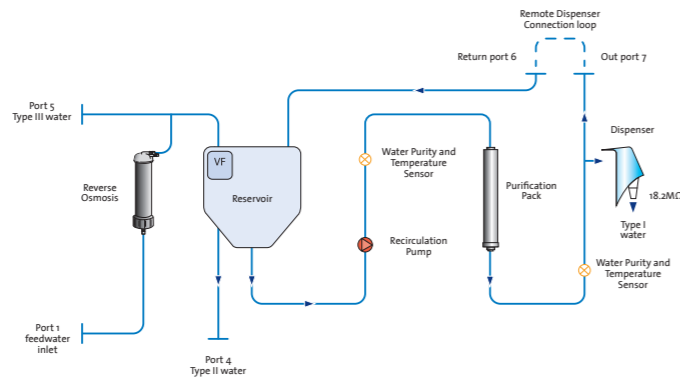

Specifications	PURELAB Quest UV	PURELAB Quest
Ultrapure (Type I) water specifications (from fixed dispense tip)		
Resistivity	18.2 MΩ.cm @ 25°C	18.2 MΩ.cm @ 25°C
Dispense flow rate	Up to 1.2 l/min (0.27 gal)	Up to 1.2 l/min (0.27 gal)
TOC	<5 ppb	<30 ppb
Bacterial TVC	<0.1 cfu/ml ^{*1}	<0.1 cfu/ml ^{*1}
Endotoxin	<0.001 Eu/ml ^{*2}	<0.001 Eu/ml ^{*2}
RNases	<1 pg/ml	n/a
DNases	<5 pg/ml	n/a
pH	Effectively Neutral	Effectively Neutral
Particulates	0.2 μm filtration ^{*1}	0.2 μm filtration ^{*1}
Recommended daily volume	Up to 10 l/day ^{*3}	Up to 10 l/day ^{*3}
Pure (Type II) water specifications (Water Outlet port 4)		
Resistivity	>1 MΩ.cm @ 25 °C	>1 MΩ.cm @ 25 °C
TOC	< 50 ppb	< 50 ppb
Bacterial TVC	<100 cfu/ml	<100 cfu/ml
Recommended daily volume	Up to 10 l/day ^{*1} (2.2 gal)	Up to 10 l/day ^{*1} (2.2 gal)

PURELAB Quest	PURELAB Quest UV
Operational weight	Operational weight
21.4 kg (47.2 lbs)	23 kg (50.7 lbs)
Installation	
Benchtop or wall-mounted	
Electrical Requirements	
Main Input	100 - 240 VAC, 50 - 60 Hz
Power Required (Excluding Pump and UV)	24 V DC
Power Consumption	120 VA
Noise Output	dBA - <40
Pipe Connections	
Inlet	8mm (5/16) OD Tube
Outlet	8mm (5/16) OD Tube
Drain	8mm (5/16) OD Tube
Reservoir Outlets	8mm (5/16) OD Tube
Reservoir Overflow	8mm (5/16) OD Tube
Environment	
Temperature	4 - 40 °C (recommended 10 - 25 °C)

Quest



Process Flow PURELAB Quest UV

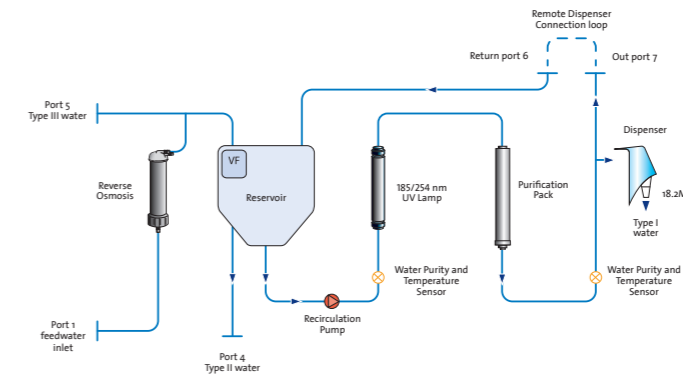

RO-permeate (Type III) Water Specifications (Water Outlet port 5)		
Conductivity	<20 μS/cm ^{*4}	<20 μS/cm ^{*4}
TOC	<200 ppb ⁴	<200 ppb ⁴
Bacterial TVC	<1000 cfu/ml ⁴	< 1000 cfu/ml ⁴
Ionic rejection	>96% ⁵	>96% ⁵
Particulates and Bacteria rejection	>99%	>99%
Organic rejection (MW > 200 Da)	>99%	>99%
Production flow	10 l/hr ⁵	10 l/hr ⁵
Recommended daily volume	Up to 30 l/day	Up to 30 l/day

^{*1} When using point of use filters (LC134/LC197)
^{*2} When using point of use filter (LC197)
^{*3} Available volume of Type I and II water combined; increased use will reduce purification pack life
^{*4} Subject to suitable feed water purity (see ionic rejection) and system maintenance
^{*5} With feed water pressure at > 4 bar and temperature at 15 °C

Feedwater Specifications	
Water Source	(Portable Water Source)
Conductivity	< 2000 μS/cm (High conductivity feedwaters may lower purification pack life and raise Type III water conductivity)
Hardness	<350 ppm as CaCO ₃
Free Chlorine	<0.05 ppm Cl ₂
Chloramine	<0.02 ppm Cl ₂
Total Chlorine	<0.05 ppm Cl ₂
Silica	<30 ppm SiO ₂
Carbon Dioxide (CO ₂)	<30 ppm (recommended < 20 ppm)
Fouling Index	<10
Iron/Manganese	<0.5 ppm Fe/Mn
TOC (Total Organic Carbon)	Recommended <2ppm

flex 1 & 2



flex 3 & 4



Process Flow PURELAB flex 1

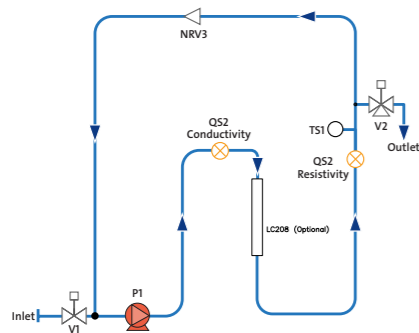

Process Flow PURELAB flex 2

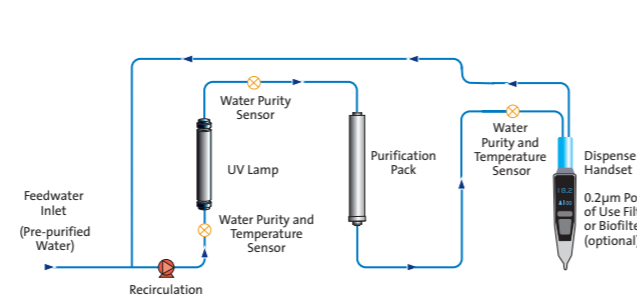

Process Flow PURELAB flex 3

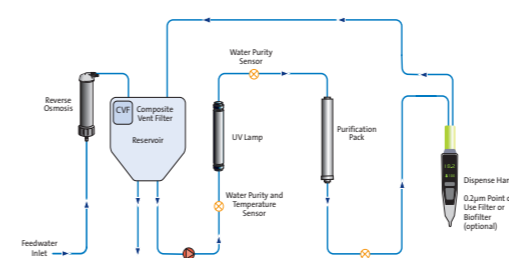

Process Flow PURELAB flex 4

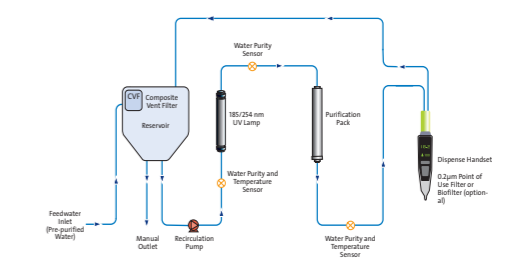

Application	PURELAB Flex 1	PURELAB Flex 1 (with purification pack)	PURELAB flex 2
Daily volume	>10 Litres	>10 Litres	>10 Litres
Dispense Flowrate	Up to 2.0 l/min	Up to 2.0 l/min	Up to 2.0 l/min
Inorganics @25°C	As per feedwater	18.2 MΩ.cm	18.2 MΩ.cm
Total organic carbon (TOC)	Dependent on feedwater		
Bacteria	<0.1 CFU/ml [°]	<0.1 CFU/ml [°]	<0.001 CFU/ml ^{°1}
Bacterial Endotoxin	N/A	<0.001 EU/ml [†]	<0.001 EU/ml [†]
RNase*	N/A	N/A	<1 pg/ml*
DNase*	N/A	N/A	<5 pg/ml*
° With C134/145/197 POU filter/Biofilter † With LC197 Biofilter ‡ Dependent on feedwater			
Source	Originally from potable supply, then pretreated. Preferably reverse osmosis (RO) or filtered service deionization (SDI) or distilled.		
Fouling index (max)	<1 for all models		
Free Chlorine	<0.05 ppm max		
TOC	N/A		
Carbon dioxide	<0.1 ppm		
Silica	<2 ppm		
Particulates	5-10 µm		
Temperature	4-40°C (Recommend 10-15°C)		
Flowrate (maximum requirement)	>2 l/min (0.5 USG)		
Drain requirements	None required		
Feedwater pressure	1.5 bar (22 psi) maximum; Flooded suction minimum		
* Fit LA652 Pressure Regulator where feedwater pressure exceeds specified limits			
Dimensions	Height 900-1020mm, Width 236mm, Depth 374mm		
Weight	10 kg (22 lbs)	10.5 kg (23.1 lbs)	11 kg (24.2 lbs)
Installation	Bench / wall		

* Values not from analyser connection

TREATED WATER SPECIFICATIONS

Application	PURELAB Flex 3	PURELAB Flex 4
Daily volume	<10 Litres	<10 Litres
Dispense Flowrate	Up to 2.0 l/min	Up to 2.0 l/min
Reverse osmosis make up flow rate at 15°C	10 l/hour	N/A
Inorganics @25°C	18.2 MΩ.cm	18.2 MΩ.cm
Total organic carbon (TOC)	<5 ppb	<5 ppb*
Bacteria	<0.001 CFU/ml [°]	<0.001 CFU/ml [°]
Bacterial Endotoxin	<0.001 EU/ml [†]	<0.001 EU/ml [†]
RNase*	<1 pg/ml	<1 pg/ml*
DNase*	<5 pg/ml	<5 pg/ml*
* Dependant on feed water ° With C134/145/197 POU filter/Biofilter † With LC197 Biofilter		

FEEDWATER REQUIREMENT

Source	Potable tap water	Originally from potable supply, then pretreated. Preferably reverse osmosis (RO) or filtered service deionization (SDI) or distilled.
Fouling index (max)	<10	<1
Free Chlorine	<0.5 ppm max	<0.05 ppm max
TOC	<2 ppm	<50 ppb recommended
Carbon dioxide	<30 ppm (recommended <20 ppm)	
Silica (recommended max)	<30 ppm	<2 ppm
Particulates	-	5-10µm
Temperature	4-40°C (Recommend 10-15°C)	
Flowrate (maximum requirement)	Up to 75 l/hr (20 USG)	Up to 75 l/hr (20 USG)
Drain requirements	<90 l/hr (23 USG)	<70 l/hr (18 USG)
Feedwater pressure	6 bar (90 psi) max; 2 bar (30 psi) min	6 bar (90 psi) max; 0.07 bar (1 psi) min
* Fit LA652 Pressure Regulator where feedwater pressure exceeds specified limits		
Dimensions	Height 900-1020mm, Width 236mm, Depth 470mm	
Weight	23 kg (57.3 lbs)	23 kg (57.3 lbs)
Installation	Bench / wall	

* Values not from analyser connection

flex 5 & 6



flex 5 & 6



Process Flow PURELAB flex 5

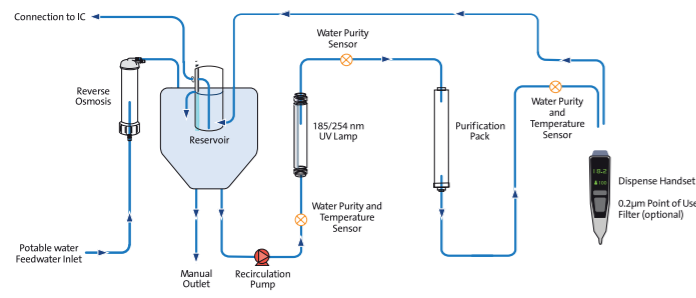

Process Flow PURELAB flex 6

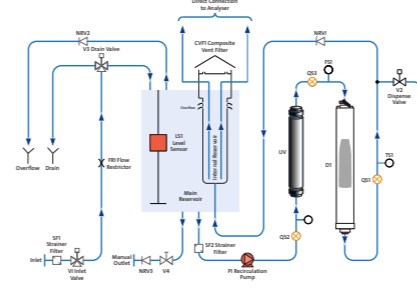

Application	PURELAB Flex 5	PURELAB Flex 6
Daily volume	<10 Litres	<10 Litres
Delivery flow rate - maximum	Up to 2.0 l/min	Up to 2.0 l/min
Recirculation flow rate	1 l/min	1 l/min
Reverse osmosis make up flow rate	10 l/hour	N/A
Inorganics (resistivity @25°C)	18.2 MΩ.cm	18.2 MΩ.cm
Organics (TOC) - typical	<5 ppb*	<5 ppb*
Direct from internal reservoir	Type III / RO Water	Type III / RO Water
Bacteria - typical (when fitted with POU filter)	<1 CFU/10ml	<1 CFU/10ml
Bacteria - typical (when fitted with Biofilter)	<1 CFU/10ml	<1 CFU/10ml
Endotoxin (when fitted with Biofilter)	<0.001 EU/ml	<0.001 EU/ml
DNase (when fitted with Biofilter)*	<20 pg/ml	<1 pg/ml*
RNase (when fitted with Biofilter)*	<0.002 ng/ml	<5 pg/ml*
* Dependant on feed water		
Source	Potable tap water	Originally from potable supply, then pretreated. Preferably reverse osmosis (RO) or filtered service deionization (SDI) or distilled.
Conductivity	<2000 µS/cm ²	<30 µS/cm
Contaminant		
Hardness	<350 ppm as CaCO ₃	<5 ppm as CaCO ₃
Hardness	<0.5 ppm Cl ₂	<0.05 ppm Cl ₂
Silica	<30 ppm SiO ₂	<2 ppm SiO ₂
Carbon Dioxide Maximum	<30 ppm (recommended <20 ppm)	<30 ppm (recommended <20 ppm)
Fouling index	<10	<1
Iron / Manganese	<0.05 ppm	N/A
Organics (TOC)	<2 ppm	<50 ppb recommended
Particulates	N/A	A 0.2 micron membrane pre filter is recommended for all non-RO feeds to extend point-of use filter life
Temperature	4 - 40oC (Recommended 10 - 25oC)	
Flowrate (requirement at 15°C)	Up to 75 l/hr	Up to 60 l/hr
Drain requirements (gravity fall with air gap)	>90L/hr	>70L/hr

² Purification pack life may vary with feedwaters >1400 µS/cm

* Values not from analyser connection

ELECTRICAL REQUIREMENTS

FEEEDWATER PRESSURE	Height 900-1020mm, Width 236mm, Depth 470mm	
Dimensions	Height 900-1020mm, Width 236mm, Depth 470mm	
Weight	23 kg (57.3 lbs)	23 kg (57.3 lbs)
Installation	Bench / wall	
ELECTRICAL REQUIREMENTS		
Maximum	90psi (6bar) ³	90psi (6bar)
Minimum	30psi (2bar) ³	1psi (0.07bar)
³ If <60psi (4 bar) a separate boost pump is recommended		
Mains input	100-240V ac, 50-60Hz	
System control voltage (not including pumps and UV)	24V dc	
Power consumption during peak demand	100VA	100VA
Noise Level	<40dBa	

Chorus 1



Chorus 1 Complete



Process Flow PURELAB Chorus 1 Life Science
- Ultrafiltration particulate filter removal of endotoxin and large molecules for Life Science Applications

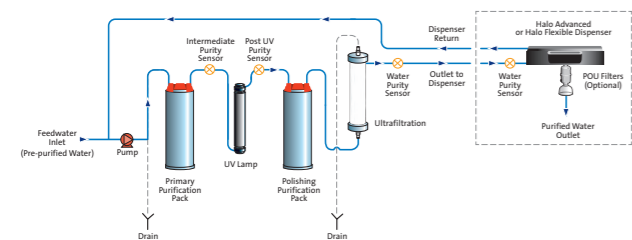

Process Flow PURELAB Chorus 1
- Ultra microfiltration to remove smaller particulates for Analytical Research Applications

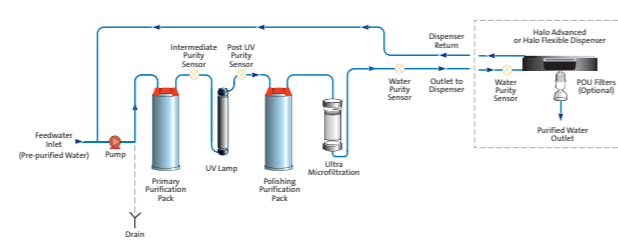

Process Flow PURELAB Chorus 1 Complete

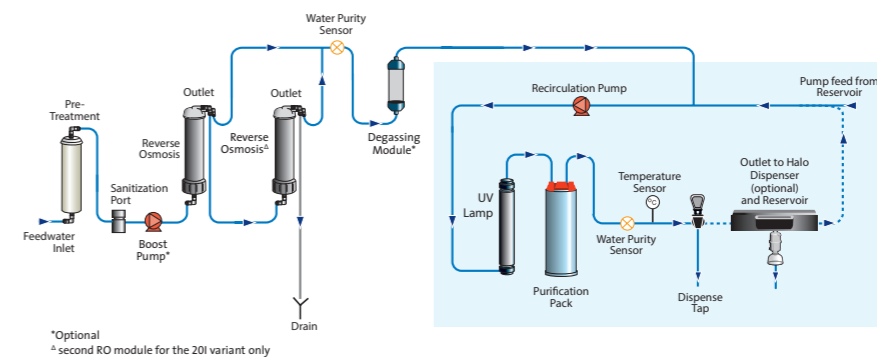

Application	Life Science	Analytical Research	General Science
Dispense Flowrate	Up to 2.0 l/min ¹	Up to 2.0 l/min ¹	Up to 2.0 l/min ¹
Inorganics @25°C	18.2 MΩ.cm	18.2 MΩ.cm	18.2 MΩ.cm
Total organic carbon (TOC)	1-3 ppb [*]	1-3 ppb [*]	3-10 ppb [*]
Bacteria	<0.001 CFU/ml ^o	<0.001 CFU/ml ^o	<0.001 CFU/ml ^o
Bacterial Endotoxin	<0.001 EU/ml ¹	<0.001 EU/ml ¹	<0.001 EU/ml ¹
pH	Effectively neutral	Effectively neutral	Effectively neutral
Particles (filtration)	<0.01 μm	<0.05 μm	0.2 μm ^o
RNase	<1 pg/ml	<1 pg/ml	
DNase	<5 pg/ml	<5 pg/ml	
Purification pack capacity	Litres to 18.2 MΩ.cm = 94,100/(μS/cm + (2.3 x ppm CO ₂))		

^{*} Dependant on feed water – recommended feed <50 ppb TOC ^o With LC134/145/197 POU filter/Biofilter ¹ When connected to Halo, Advanced or flexible ¹ With LC197 Biofilter

Source – originally from potable supply, then pretreated	Preferably RO produced by PURELAB Chorus 3 or filtered service deionization (SDI) or distilled. Note: mixed bed or twin bed deionized supplies should be cation limited at exhaustion		
Fouling index (max)	1 for all models. A 5-10 micron membrane prefilter is recommended for all non-RO feeds		
Service deionization (SDI) – MΩ.cm	1 MΩ.cm minimum resistivity at exhaustion		
Reverse Osmosis (RO) – μS/cm	Recommended <30 μS/cm		
Free Chlorine	0.05 ppm max		
TOC	<50 ppb max (RO feed)		
Carbon dioxide	30 ppm (max recommended)		
Silica	2 ppm (max recommended)		
Particulates	Filtration down to 5-10 micron advisable to protect internal and/or point of use filters		
Temperature	1-35°C (Recommend 10-15°C)		
Flowrate (maximum requirement)	130 l/hr (34 USG)		
Drain requirements	Up to 2 l/min (0.5 USG)		
Feedwater pressure	0.7 bar (10 psi) maximum; 0.07 bar (1 psi) minimum		
[*] Fit LA652 Pressure Regulator where feedwater pressure exceeds specified limits			
Dimensions	Height 435mm, Width 375mm, Depth 340mm		
Weight	19 kg (42 lbs)	19 kg (42 lbs)	18 kg (40 lbs)

Application	PURELAB Chorus Complete	
Nominal output at 15°C	10 l/hr	20 l/hr
Dispense Flowrate	>1.5 l/min	>1.5 l/min
Inorganics @25°C	18.2 MΩ.cm	18.2 MΩ.cm
Total organic carbon (TOC)	<5 ppb	<5 ppb
Bacteria	<0.001 CFU/ml ^o	<0.001 CFU/ml ^o
Bacterial Endotoxin	<0.001 EU/ml ¹	<0.001 EU/ml ¹
pH	Effectively neutral	Effectively neutral
Particles (filtration)	0.2 μm ¹	0.2 μm ¹
RNase	<1 pg/ml	<1 pg/ml
DNase	<5 pg/ml	<5 pg/ml
Purification pack capacity	Litres to 18.2 MΩ.cm = 94,100/(μS/cm + (2.3 x ppm CO ₂))	

^o With LC134/145/197 POU filter/Biofilter ¹ With LC197 Biofilter ¹ With LC134/145 POU filter

Source	Potable mains water supply	
Fouling index (max)	<10	
Free Chlorine	0.5 ppm max	
Carbon dioxide	Ideally <20 ppm	
Silica	30 ppm (max recommended)	
Temperature	1-35°C (Recommend 10-15°C)	
Flowrate (maximum requirement)	130 l/hr (34 USG)	
Drain requirements	Up to 2 l/min (0.5 USG)	
Feedwater pressure	4.0 bar (60 psi) min; 6 bar (90 psi) max [*] With boost pump: flooded suction (min) to 2.0 bar (30 psi) max	
[*] Fit LA652 Pressure Regulator where feedwater pressure exceeds specified limits		
Dimensions	Height 679mm, Width 376mm, Depth 353mm	
Weight (with boost pump)	17 kg (38 lbs)	18 kg (40 lbs)
Weight	15 kg (33 lbs)	16 kg (36 lbs)

Pharma Compliance



Chorus 2+



Pharma Compliance Flow Diagram

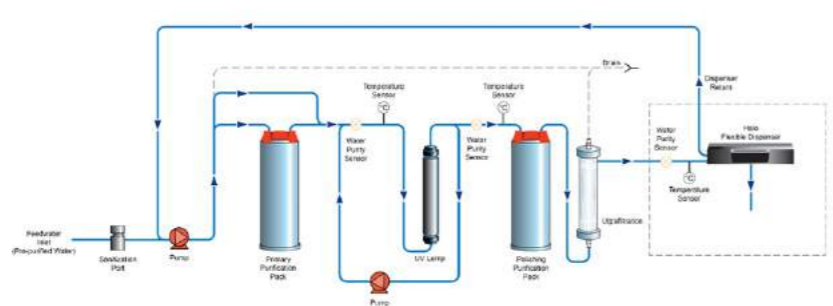

Process Flow PURELAB Chorus 2+ (RO/DI/UV)

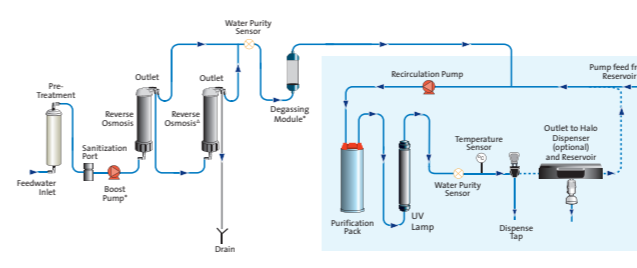

Process Flow PURELAB Chorus 2+ (RO/DI/UV)

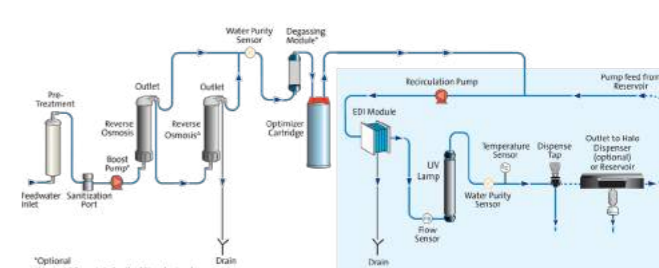

Application	Pharma Compliance - VCLSM1
Resistivity	18.2 MΩ-cm
Dispenser flow-rate	up to 2 L/min
Total Organic Carbon (TOC)	1 – 3 ppb
Bacterial Endotoxin	<0.001 EU/ml
Bacterial Spec	<0.001 CfU/ml with a LC134 or LC145 or LC197 Point-of-use 0.2µm Micron filter fitted.
DNases	<5 pg/ml
RNases	<1 pg/ml
Particles	<0.01 µm
Recirculation Mode	During periods of non-use the unit will automatically operate in intermittent (10 minutes every 1 hours) re-circulation mode to maintain water purity with maximum efficiency.
Water Source	Pre-treated preferably RO, SDI or distilled.
Fouling Index (max)	1 for all models. A 5 – 10 micron pre-filter is recommend for all non RO feeds.
Service Deionization (SDI)	1MΩ.cm minimum at exhaustion.
Reverse Osmosis (RO)	Recommend <30 µS/cm
Free Chlorine (max)	0.05 ppm
TOC	0.05 ppm max
Carbon Dioxide	30 ppm max
Silica	2 ppm max
Particulates	Filtration down to 0.2 micron advisable.
Temperature	1 – 40°C (Recommended 10 – 15°C)
Maximum Inlet Pressure	0.7 bar (10 psi) Fit a LA652 Pressure Regulator where feedwater exceeds specified limits.
Minimum Inlet Pressure	0.07 bar (1 psi)
Flowrate	130 l/hr (34 USG)
Drain Requirements	Up to 2 l/min (0.5 USG) (Gravity fall with air gap) Max during service.

Optimize your water purity at the point of use:

- Biofilter: Endotoxin removal (<0.001 EU/ml), DNase removal (<20pg/ml), RNase removal (<0.002ng/ml)
- Microfilter: Particulate removal (≥0.2 µm)

TREATED WATER SPECIFICATIONS

Application	PURELAB Chorus 2+ (RO/DI/UV)		PURELAB Chorus 2+ (RO/EDI/UV)	
Nominal output at 15°C	10 l/hr*	20 l/hr*	10 l/hr*	20 l/hr*
Nominal daily output	240 l/day	480 l/day	240 l/day	480 l/day
Inorganics @25°C	10- >15 MΩ.cm		10- >15 MΩ.cm	
Organics (MW>200 Dalton)	>99% rejection		>99% rejection	
Total organic carbon (TOC)	<10 ppb		<10 ppb	
Bacteria	<0.001 CFU/ml ^o		<0.001 CFU/ml ^o	
pH	Effectively neutral		Effectively neutral	
Particles (filtration)	0.2µm ^o		0.2µm ^o	
Purification pack capacity	Litres to 15 MΩ.cm = 74,700/(µS/cm + (2.3 x ppm CO ₂))		Litres to 15 MΩ.cm = 74,700/(µS/cm + (2.3 x ppm CO ₂))	

* Standard conditions are 4 bar inlet pressure at 15°C, fed with potable water and a clean pre-treatment cartridge. Refer to flow tables outside these conditions. ^o With LC134/145 POU filter

FEEDWATER REQUIREMENT

Source	Potable mains water supply	Potable mains water supply
Fouling index (max)	<10	<10
Conductivity	<2000 µS/cm	<2000 µS/cm
Free Chlorine	0.5 ppm max	0.5 ppm max
Heavy Metals (max)	0.05 ppm	0.05 ppm
Silica	30 ppm	30 ppm
Temperature	1-35°C	1-35°C
Flowrate (maximum requirement)	100 l/hr (27 USG)	100 l/hr (27 USG)
Drain requirements	80 l/hr (21 USG)	80 l/hr (21 USG)
Feedwater pressure	4.0 bar (60 psi) min; 6 bar (90 psi) max* With boost pump: flooded suction (min) to 2.0 bar (30 psi) max	4.0 bar (60 psi) min; 6 bar (90 psi) max* With boost pump: flooded suction (min) to 2.0 bar (30 psi) max

*Fit LA652 regulator where feedwater pressure exceeds specified limits

Dimensions	Height 679mm, Width 376mm, Depth 353mm		Height 679mm, Width 376mm, Depth 353mm	
Weight (with boost pump)	17 kg (37 lbs)	18 kg (40 lbs)	17 kg (37 lbs)	18 kg (40 lbs)
Weight	15 kg (33 lbs)	16 kg (35 lbs)	15 kg (33 lbs)	16 kg (35 lbs)

Chorus 2 & 3



Process Flow PURELAB Chorus 2 (RO/DI)

Process Flow PURELAB Chorus 3 (RO)

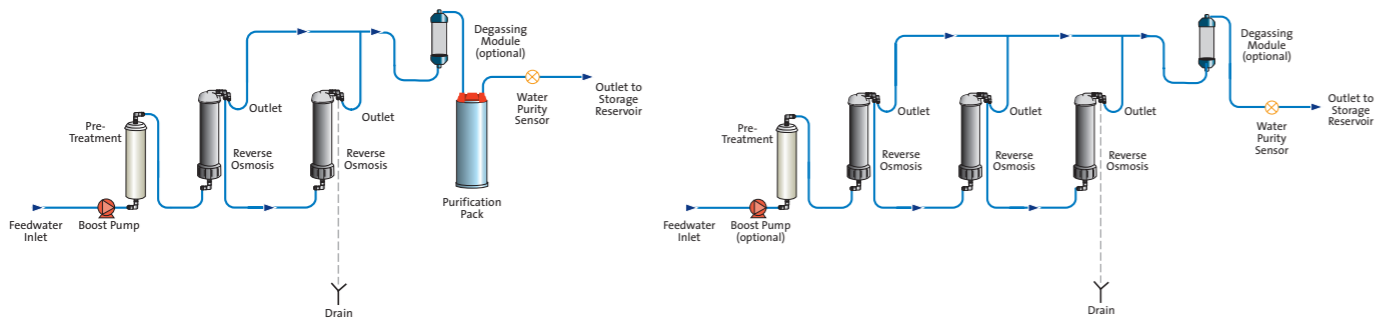

Application	PURELAB Chorus 2 (RO/DI)		PURELAB Chorus 3 (RO)		
Nominal output at 15°C	10 l/hr	20 l/hr	10 l/hr	20 l/hr	30 l/hr
Nominal daily output	240 l/day	480 l/day	240 l/day	480 l/day	720 l/day
Inorganics @25°C	1 to >10 MΩ.cm		>95% rejection		
Organics (MW>200 Dalton)	>99% rejection		>95% rejection		
Total organic carbon (TOC)	<30 ppb		<50 ppb		
Bacteria*	<5 CFU/ml		<50 CFU/ml		
pH	Effectively neutral		Effectively neutral		
Particles	>99% rejection		>99% rejection		
Purification pack capacity	Litres to 1MΩ.cm = 103,200/(μS/cm + (2.3 x ppm CO ₂))		N/A		
Standard conditions are 4 bar inlet pressure at 15°C, fed with potable water and a clean pre-treatment cartridge. Refer to flow tables outside these conditions. * Bacterial specification is before the water goes into the reservoir					
Source – originally from potable supply, then pretreated	Potable mains water supply		Potable mains water supply		
Fouling index (max)	10		10		
Conductivity	<2000 μS/cm		<2000 μS/cm		
Free Chlorine	0.5 ppm max		0.5 ppm max		
Heavy Metals (max)	0.05 ppm		0.05 ppm		
Silica	30 ppm		30 ppm		
Temperature	1-35°C		1-35°C		
Flowrate (maximum requirement)	100 l/hr (27 USG)		100 l/hr (27 USG)		
Drain requirements	80 l/hr (21 USG)		80 l/hr (21 USG)		
Feedwater pressure	2.0 bar (30 psi) maximum; 0.5 bar (7.5 psi) minimum**		2.0 bar (30 psi) maximum; 0.5 bar (7.5 psi) minimum**		
**Fit LA652 Regulator where feedwater pressure exceeds specified limits					
Dimensions	Height 435mm, Width 375mm, Depth 340mm				

Find your product



	Chorus 1					Chorus 2 & 3				flex						Quest	
	Life Science	Analytical Research	General Science	1 Complete	Pharma Compliance	2+ (RO/EDI/UV)	2+ (RO/DI/UV)	2 (RO/DI)	3 (RO)	flex 1	flex 2	flex 3	flex 4	flex 5	flex 6	UV	Non UV
Water Type																	
Ultrapure Type I	✓	✓	✓	✓	✓					✓*	✓	✓	✓	✓	✓	✓	✓
Pure Type II						✓	✓	✓		✓*						✓	✓
RO Type III										✓*		✓	✓	✓	✓	✓	✓
Impurities to remove																	
Nucleases	✓	✓	✓	✓	✓	✓	✓				✓	✓	✓	✓	✓	✓	✓
Endotoxins/Pyrogens	✓	✓ ^o	✓ ^o	✓ ^o	✓ ^o	✓ ^o	✓ ^o				✓ ^o	✓ ^o	✓ ^o	✓ ^o	✓ ^o	✓ ^o	✓ ^o
Inorganics	✓	✓	✓	✓	✓	✓	✓	✓	✓	✓	✓	✓	✓	✓	✓	✓	✓
Organics	✓	✓	✓	✓	✓	✓	✓	✓	✓	✓	✓	✓	✓	✓	✓	✓	✓
Bacteria	✓	✓	✓	✓	✓	✓	✓	✓	✓	✓ ^Δ	✓	✓	✓	✓	✓	✓	✓
Particulates	✓	✓	✓ ^Δ	✓	✓	✓	✓	✓	✓	✓ ^Δ	✓ ^Δ	✓ ^o	✓ ^o	✓	✓	✓	✓
Features																	
PureSure®	✓	✓	✓		✓												
Real time TOC monitoring	✓	✓			✓						✓	✓	✓	✓			
Potable tap water				✓		✓	✓				✓	✓	✓	✓	✓	✓	✓
Wall mounting	✓	✓	✓	✓	✓	✓	✓	✓	✓	✓	✓	✓	✓	✓	✓	✓	✓
Floor mounting	✓	✓	✓	✓	✓	✓	✓	✓	✓								
Purity monitoring to POU	✓	✓	✓	✓	✓	✓	✓			✓	✓	✓	✓	✓	✓	✓	✓
Halo Dispense compatible	✓	✓	✓	✓	✓	✓	✓	✓									
Remote Dispense																✓	✓
Auto Volume Dispense	✓ [†]	✓ [†]	✓ [†]	✓ [†]	✓	✓ [†]	✓ [†]			✓	✓	✓	✓	✓	✓	✓	✓
Variable flow rate dispense	✓ [†]	✓ [†]	✓ [†]	✓ [†]	✓	✓ [†]	✓ [†]			✓	✓	✓	✓	✓	✓	✓	✓
Drop-by-drop control	✓ [†]	✓ [†]	✓ [†]	✓ [†]	✓	✓ [†]	✓ [†]			✓	✓	✓	✓	✓	✓	✓	✓
Locked dispense	✓ [†]	✓ [†]	✓ [†]	✓ [†]	✓	✓ [†]	✓ [†]			✓	✓	✓	✓	✓	✓	✓	✓
USB connection	✓	✓	✓	✓	✓	✓	✓	✓	✓	✓	✓	✓	✓	✓	✓	✓	✓
Full product validation*	✓	✓	✓	✓	✓	✓	✓	✓	✓	✓	✓	✓	✓	✓	✓	✓	✓

With DI cartridge * No DI cartridge ^o With LC197 POU filter ^Δ With LC134/145 POU filter ~ 0.2mm
[†] When fitted with a Halo dispense solution
 ** Full product validation needs to be purchased separately.

Find your product



	Chorus 1					Chorus 2 & 3				PURELAB flex						Quest	
	Life Science	Analytical Research	General Science	1 Complete	Pharma Compliance	2+ (RO/EDI/UV)	2+ (RO/DI/UV)	2 (RO/DI)	3 (RO)	flex 1	flex 2	flex 3	flex 4	flex 5	flex 6	UV	Non UV
Ideal solution for Systems also have wider applicability. Speak to your local ELGA specialist for further information.																	
Cell culture	✓			✓						✓ ^Δ	✓ ^Δ	✓ ^Δ	✓ ^Δ	✓ ^Δ	✓ ^Δ	✓ ^Δ	✓ ^Δ
Liquid Chromatography (HPLC, UHPLC)	✓	✓		✓						✓	✓	✓	✓	✓	✓	✓	✓
Microbiological Analysis	✓	✓		✓						✓	✓	✓	✓	✓	✓	✓	✓
Genetic (PCR, DNA/RNA sequencing, DNA, Nucleic acid)	✓																
Gas Chromatography		✓		✓						✓	✓	✓	✓	✓	✓	✓	✓
Electrochemistry		✓	✓	✓		✓	✓			✓	✓	✓	✓	✓	✓	✓	✓
Immunochemistry	✓			✓						✓	✓	✓	✓	✓	✓	✓	✓
Atomic Spectroscopy (Flame AA, GFAA, ICP-AE)		✓	✓	✓						✓	✓	✓	✓	✓	✓	✓	✓
Mass Spectrometry (ICP-MS, GC-MS, LC-MS)	✓	✓		✓						✓	✓	✓	✓	✓	✓	✓	✓
General lab water requirement (glassware washing, heating baths, autoclave filling)				✓			✓	✓	✓ [*]		✓			✓		✓	✓
Spectrophotometry (inc. UV, IR, near UV, nearIR)				✓		✓	✓			✓	✓	✓	✓	✓	✓	✓	✓
Feed to ultrapure water system						✓	✓	✓	✓								
Media/buffer preparation (inc pH solution)						✓	✓	✓								✓	✓
General chemistry (inc Titrimetry)		✓	✓			✓	✓	✓	✓	✓	✓	✓	✓	✓	✓	✓	✓

Product Part Numbers

PURELAB Quest	Description
Part Number	
PQDIXXM1NSP	PURELAB Quest
PQDIXXM1	PURELAB Quest with starter pack
PQDIUVM1NSP	PURELAB Quest UV
PQDIUVM1	PURELAB Quest UV with starter pack

All units - User Manual (MANU41196), Certificate of Conformity, POWE38971-02, LA728 (Bypass Pack)
 PURELAB Quest - 1x LC217
 PURELAB Quest (With Starter Pack) 1x LC217, 1x LC291, 1x LC292
 PURELAB Quest UV - 1x LC217, 1x LC210
 PURELAB Quest UV (With Starter Pack) 1x LC217, 1x LC292, 1x LC291, 1x LC210

PURELAB flex	Description
Part Number	
PF1-M2	PURELAB flex 1 (optional Purification Pack)
PF2-M2	PURELAB flex 2 (Purification Pack + UV + TOC)
PF3-M2	PURELAB flex 3
PF4-M2	PURELAB flex 4
PF5-M2	PURELAB flex 5
PF6-M2	PURELAB flex 6

Unit is supplied as standard with: All units: quick Reference Guide & user manual, certificate of conformity, bypass pack. Flex 2: 1 x LC210.
 Flex 3 & 5: 1 x LC217, 1 x LC210, 1 x LC216. Flex 4 & 6: 1 x LC210, 1 x LC216.

PURELAB Chorus 1	Description
Part Number	
PC1ANRXM2	PURELAB Chorus 1 Analytic Research Ultrapure System
PC1LSCXM2	PURELAB Chorus 1 Life Science Ultrapure System
PC1GSCXM2	PURELAB Chorus 1 General Science Ultrapure System

Unit is supplied as standard with: Fitted/Included: appropriate consumables (including 2 x LC232 - see list below), MANU39998/MANU39997/MANU40001 Operator Manual, GUID39864 Light Guide, GUID40005 Quick Reference Guide, INST40012 Quick Start Guide, LA762 basic installation kit, LC233 x 2 bypass block.

PURELAB Chorus 1 Complete	Description
Part Number	
PC110COXXM1	PURELAB Chorus 1 Complete 10 l/hr System
PC110COBPM1	PURELAB Chorus 1 Complete 10 l/hr System with Boost Pump
PC120COXXM1	PURELAB Chorus 1 Complete 20 l/hr System
PC120COBPM1	PURELAB Chorus 1 Complete 20 l/hr System with Boost Pump

Unit is supplied as standard with: Fitted/Included: appropriate quantity LC240, 1 x LC241, 1 x LC275, 1 x LC272, 1 x LC210, MANU40932 Operator Manual, GUID39864 Light Guide, LA762 Basic installation Kit.

PURELAB Pharma Compliance	Description	Dispenser
Part Number		
VCLSDM1	PURELAB Pharma Compliance	1x Halo
VCLSDM1-D1	PURELAB Pharma Compliance with 1x Dispenser	1x Halo, 1x Dispenser
VCLSDM1-D2	PURELAB Pharma Compliance with 2x Dispenser Biofilter fitted	1x Halo, 2x Dispenser
VCLSDM1-D3	PURELAB Pharma Compliance with 3x Dispenser	1x Halo, 3x Dispenser

PURELAB Chorus 2+ RO/EDI/UV	Description
Part Number	
PC210EUXXM1	PURELAB Chorus 2+ RO/EDI/UV 10 l/hr System
PC210EUBPM1	PURELAB Chorus 2+ RO/EDI/UV 10 l/hr System with Boost Pump
PC220EUXXM1	PURELAB Chorus 2+ RO/EDI/UV 20 l/hr System
PC220EUBPM1	PURELAB Chorus 2+ RO/EDI/UV 20 l/hr System with Boost Pump

Unit is supplied as standard with: Fitted/Included: appropriate quantity LC240, 1 x LC241, 1 x LC243, 1 x LC277, 1 x LC285, 1 x LC233, MANU40932 Operator Manual, GUID39864 Light Guide, LA762 Basic installation Kit

PURELAB Chorus 2+ RO/DI/UV	Description
Part Number	
PC210DUXXM1	PURELAB Chorus 2+ RO/DI/UV 10 l/hr System
PC210DUBPM1	PURELAB Chorus 2+ RO/DI/UV 10 l/hr System with Boost Pump
PC220DUXXM1	PURELAB Chorus 2+ RO/DI/UV 20 l/hr System
PC220DUBPM1	PURELAB Chorus 2+ RO/DI/UV 20 l/hr System with Boost Pump

Unit is supplied as standard with: Fitted/Included: appropriate quantity LC240, 1 x LC241, 1 x LC272, 1 x LC274, 1 x LC285, MANU40932 Operator Manual, GUID39864 Light Guide, LA762 Basic installation Kit.

PURELAB Chorus 2 RO/DI	Description
Part Number	
PC210DIXXM3	PURELAB Chorus 2 RO/DI 10 l/hr System
PC210DIBPM3	PURELAB Chorus 2 RO/DI 10 l/hr System with Boost Pump
PC220DIXXM3	PURELAB Chorus 2 RO/DI 20 l/hr System
PC220DIBPM3	PURELAB Chorus 2 RO/DI 20 l/hr System with Boost Pump

Unit is supplied as standard with: Fitted/Included: appropriate quantity LC240 RO, 1 x LC241, 1 x LC234, MANU40003, Operator Manual, GUID39864 Light Guide, GUID40005 Quick Reference Guide, INST40009 Quick Start Guide, LA762 basic installation kit, LC233 bypass block



Product Part Numbers

PURELAB Chorus 3 Part Number	Description
RO310XXM3	PURELAB Chorus 3 RO 10 l/hr
RO310BPM3	PURELAB Chorus 3 RO 10 l/hr with Boost Pump
RO320XXM3	PURELAB Chorus 3 RO 20 l/hr
RO320BPM3	PURELAB Chorus 3 RO 20 l/hr with Boost Pump
RO330XXM3	PURELAB Chorus 3 RO 30 l/hr
RO330BPM3	PURELAB Chorus 3 RO 30 l/hr with Boost Pump

Unit is supplied as standard with: Fitted/Included: appropriate quantity LC240 RO, 1 x LC241, GUID39864 Light Guide, GUID40004 Quick Reference Guide, INST40008 Quick Start Guide, LA762 basic installation kit



PURELAB Chorus Reservoirs Part Number	Description
LA757	15 Litre Reservoir
LA758	30 Litre Reservoir
LA759	60 Litre Reservoir
LA760	100 Litre Reservoir

Each reservoir supplied with LA773 Installation Kit & LC216 Composite Vent Filter



PURELAB Dispenser Part Number	Description
LA826	PURELAB Dispenser Installation Kit
LA827	(Worktop) Bench Mounting Bracket Kit
LC134	Point-Of-Use 0.2µm Filter (POU). Recommended Change: 3 months
LC145	Point-Of-Use 0.2µm Filter (POU). Recommended Change: 3 months
LC197	Point-Of-Use Bio Filter (POU). Recommended Change: 3 months
CEPWGU303754	Power Supply

Unit is supplied as standard with: 1 x LA826 Installation kit & MANU41319 Operator manual. PURELAB Dispenser Installation kit & accessories



PURELAB Chorus Halo Dispensers Part Number	Description
LA754	Halo Dispenser
LA755	Advanced Halo Dispenser
LA756	Flexible Dispenser

Each supplied with GUID40007 or GUID40006 Quick Reference Guide, INST40011 or INST40013 Quick Start Guide, LA774 Installation Kit (plus for LA756: MANU40002 Operator manual)



Dedicated to Discovery

info@elgalabwater.com / www.elgalabwater.com

ELGA Labwater are specialists in the engineering, service & support of water purification systems.

Unrivalled product design has achieved international recognition and awards.

Worldwide technical service teams support science & healthcare globally with specialist expertise.

Global digital performance monitoring from Hubgrade ensures laboratory work is uninterrupted.

A global supply chain supports clients from regional centres on every continent.

To find your nearest ELGA representative, go to www.elgalabwater.com and select your country for contact details.

Elga Global Operations Centre.

tel: +44 (0) 203 567 7300

fax: +44 (0) 203 567 7205



Hubgrade



OVER 80 INTERNATIONAL PATENTS